

ICS 91.040.99

English Version

Temporary structures - Tents - Safety

Structures temporaires - Tentes - Sécurité

Fliegende Bauten - Zelte - Sicherheit

This European Standard was approved by CEN on 19 October 2005.

CEN members are bound to comply with the CEN/CENELEC Internal Regulations which stipulate the conditions for giving this European Standard the status of a national standard without any alteration. Up-to-date lists and bibliographical references concerning such national standards may be obtained on application to the Central Secretariat or to any CEN member.

This European Standard exists in three official versions (English, French, German). A version in any other language made by translation under the responsibility of a CEN member into its own language and notified to the Central Secretariat has the same status as the official versions.

CEN members are the national standards bodies of Austria, Belgium, Cyprus, Czech Republic, Denmark, Estonia, Finland, France, Germany, Greece, Hungary, Iceland, Ireland, Italy, Latvia, Lithuania, Luxembourg, Malta, Netherlands, Norway, Poland, Portugal, Slovakia, Slovenia, Spain, Sweden, Switzerland and United Kingdom.



EUROPEAN COMMITTEE FOR STANDARDIZATION
COMITÉ EUROPÉEN DE NORMALISATION
EUROPÄISCHES KOMITEE FÜR NORMUNG

Management Centre: rue de Stassart, 36 B-1050 Brussels

Contents

Page

Foreword	4
Introduction	5
1 Scope	6
2 Normative references	6
3 Terms and definitions	7
4 General requirements for design, analysis and examination	8
4.1 Design documents	8
4.2 Description of construction and operation	8
4.3 Construction drawings	8
5 Principles of numerical analysis	8
5.1 Verification	8
5.2 Selection of textile materials	9
6 Design actions	10
6.1 General	10
6.2 Permanent actions	10
6.3 Conventional load	10
6.4 Variable actions	10
6.5 Seismic forces	15
6.6 Load combinations	15
7 Verification of stability and equilibrium	16
7.1 General	16
7.2 Verification against overturning, sliding and lifting	17
7.3 Dead load for tent covers	19
7.4 Structures with primary load bearing structure (i.e. roof, truss, tents)	19
7.5 Membrane	19
7.6 Verification of load bearing capacity of technical textiles and their connections	20
7.7 Safety margin, safeguards	21
7.8 Post tensioning	21
8 Ground anchorages	22
8.1 General	22
8.2 Load bearing capacity of weight anchors	22
8.3 Load bearing capacity of rod anchors	22
8.4 Testing of anchors	25
9 Other structural components	25
9.1 Cables, ropes, chains, safety devices	25
9.2 Accessories	27
9.3 Ratchets	27
9.4 Detail connections	27
10 Special design and manufacture criteria	27
11 Manufacture and supply	27
11.1 General	27
11.2 Certificates	28
11.3 Observation of the design specification	28
11.4 Description of installation and operation procedures	28
12 Examination	28
12.1 General	28
12.2 Qualification	28

12.3	Competence	29
13	Procedures for approval, examination and tests	29
13.1	General	29
13.2	Identification.....	29
13.3	Initial approval of tents	29
13.4	Inspection after repair, modification and accidents.....	30
13.5	Report	30
14	Tent book.....	30
14.1	General	30
14.2	Content	30
15	Use and operation.....	31
Annex A (informative) Burning behaviour		32
Annex B (informative) Aerodynamic coefficients for round shape tents		36
Annex C (informative) Special design and manufacture criteria		37
C.1	Access to and egress from enclosures, shows and others.....	37
C.2	Burning behaviour	37
C.3	Connection and weldings.....	37
Annex D (informative) Use and operation.....		39
D.1	Periodic thorough examination	39
D.2	Installation examination	39
D.3	Escape routes	40
D.4	Stairs.....	40
D.5	Heating and cooking systems.....	40
D.6	Electrical fittings	41
D.7	Fire extinguishers	41
Bibliography.....		42

Foreword

This European Standard (EN 13782:200:2005) has been prepared by Technical Committee CEN/TC 152, "Fairground and amusement park machinery and structures - Safety", the secretariat of which is held by UNI.

European Standard shall be given the status of a national standard, either by publication of an identical text or by endorsement, at the latest by May 2006, and conflicting national standards shall be withdrawn at the latest by May 2006.

Within the framework of its programme of work, CEN/TC 152 requested the WG 2 "Tents" to prepare a European Standard dealing with the safety of tents installed in fairground and amusement parks.

According to the CEN/CENELEC Internal Regulations, the national standards organizations of the following countries are bound to implement this European Standard: Austria, Belgium, Cyprus, Czech Republic, Denmark, Estonia, Finland, France, Germany, Greece, Hungary, Iceland, Ireland, Italy, Latvia, Lithuania, Luxembourg, Malta, Netherlands, Norway, Poland, Portugal, Slovakia, Slovenia, Spain, Sweden, Switzerland and United Kingdom.



Introduction

The object of this European Standard is to provide safety requirements for tents. The safety requirements are aimed to safe-guard persons and objects against damage caused by design, manufacturing and operation of these structures.

These guidelines have been drawn up according to past experience and risk analysis.

Existing national rules concerning health and safety of workers remain untouched.



EN 13782:2005 (E)**1 Scope**

This European Standard specifies safety requirements which need to be observed at design, calculation, manufacture, installation, maintenance, operation, examination and testing of mobile, temporary installed tents more than 50 m² ground area. For tents less than 50 m² ground area, it is not necessary to produce the tent book (see Clause 14) and the producer will provide a documentation concerning the burning behaviour of the fabrics and the stability of the structure.

Two tents can be considered as two tents if the distance between them is more than 5 m except otherwise agreed.

These tents are intended to be installed and dismantled repeatedly without loss of substance, temporarily as well as on short term or long-term basis at any places, and multiple purposes.

A simplified calculation for tents with a maximum space of 12 m and a maximum capacity of 300 people is allowed for traditional pole and rope tents.

The field of application of this European Standard covers all kind of temporary covered structures.

Tents erected for a temporary period and dismantled for use elsewhere in fairgrounds and amusement parks are covered by this European Standard.

The content of this European Standard collects the different existing national regulations and guidelines as far as possible.

2 Normative references

The following referenced documents are indispensable for the application of this European Standard. For dated references, only the edition cited applies. For undated references, the latest edition of the referenced document (including any amendments) applies.

EN 818 (all parts), *Short link chain for lifting purposes — Safety*

EN 1677-2, *Components for slings — Safety — Part 2: Forged steel lifting hooks with latch, Grade 8*

EN 1677-5, *Components for slings — Safety — Part 5: Forged steel lifting hooks with latch — Grade 4*

EN 1991-1-1, *Eurocode 1: Actions on structures — Part 1-1: General actions — Densities, self-weight and imposed loads for buildings*

EN 1991-1-2, *Eurocode 1: Actions on structures — Part 1-2: General actions — Actions on structures exposed to fire*

EN 1991-1-3, *Eurocode 1 — Actions on structures — Part 1-3: General actions — Snow loads*

EN 1991-1-4, *Eurocode 1: Actions on structures - Part 1-4: General actions - Wind actions*

EN 1997-1, *Eurocode 7: Geotechnical design - Part 1: General rules*

EN 10204:2004, *Metallic products — Types of inspection documents*

EN 12385-1, *Steel wire ropes — Safety — Part 1: General requirements*

EN 12385-2, *Steel wire ropes — Safety — Part 2: Definitions, designation and classification*

EN 12385-3, *Steel wire ropes — Safety — Part 3: Information for use and maintenance*

EN 12385-4, *Steel wire ropes — Safety — Part 4: Stranded ropes for general lifting applications*

EN 12385-5, *Steel wire ropes — Safety — Part 5: Stranded ropes for lifts*

EN 12385-6, *Steel wire ropes — Safety — Part 6: Stranded ropes for mine shafts*

EN 12385-7, *Steel wire ropes — Safety — Part 7: Locked coil ropes for mine shafts*

EN 12385-8, *Steel wire ropes — Safety — Part 8: Stranded hauling and carrying-hauling ropes for cableway installations designed to carry persons*

EN 12385-9, *Steel wire ropes — Safety — Part 9: Locked coil carrying ropes for cableway installations designed to carry persons*

ISO 2602, *Statistical interpretation of test results — Estimation of the mean — Confidence interval*

3 Terms and definitions

For the purposes of this European Standard, the following terms and definitions apply.

3.1

tent

mobile, temporary installed structure enclosed or open building i.e.: marquee, hangar, tent-hall, booth, grandstand-cover

3.1.1

tent with primary load-bearing structure

tent with load bearing support structured and enclosing elements

3.1.2

membrane tent

tent with a load bearing pre-stressed textile structure with double curved shape, supported by mast and/or cable system

3.1.3

traditional pole tent

tent with centre poles, and extensive use is made of guying to stabilise the fabric covering

3.2

initial approval

design and calculation review, verification, examinations and tests executed before granting a permit for tent operation

3.3

modification

any alteration of a tent, including the introduction of a safety critical component or a substitution of a safety critical component which results in a departure from the original design specification

3.4

repair

restoration of safety critical components or safety critical assemblies back to the original specification by the mending of worn, damaged or decayed parts

3.5

maintenance

replacement or replenishment of components which are designed to be replaced at specified intervals

EN 13782:2005 (E)**4 General requirements for design, analysis and examination****4.1 Design documents**

The design documents shall include information for the verification of the stability, resistance and operating safety, especially a description of the construction and operation, the stability verification and design drawings as well as relevant documents concerning the burning behaviour.

The documents shall include all the possible configurations of the tent.

4.2 Description of construction and operation

The tent in particular its design and utilisation and its static system shall be explained in this description.

The description shall include details of the particular features of the tents and of any alternative modes of installation which may exist, also details of the main dimensions, limitations, design particulars and materials.

4.3 Construction drawings

These shall exist for all sub assemblies and individual components, the fracture or failure of which might endanger, the stability or operating safety of the tent.

The construction drawings shall feature all the dimensions and cross section values required for testing and approval, also details of materials, structural components, fasteners and connectors.

The construction plans shall comprise the following:

- general drawings in plan view, elevation and sections, to one of the following scales, i.e., 1:100, 1:50 or 1:20. If clearness and readability does not suffice other scales shall be used;
- detail drawings relating to all the structural subassemblies not clearly discernible on the general drawings, also detail plans of connections and of individual items of structural nature which are likely to affect the safety of the tent and of its operation, drawn to a larger scale.

5 Principles of numerical analysis**5.1 Verification**

5.1.1. In general, if subsequently not determined differently, the verification shall follow the relevant Part of Eurocode 1 and shall comprise:

- limit states analysis (according to theory of 1st or 2nd order);
- stability limit states analysis, i.e. bar buckling plate and shell buckling;
- if required, verification of deformation limit states;
- verification of safety against overturning, sliding and lifting off.

5.1.2 The above mentioned verification shall include the following details, amongst others:

- design loads, taking into account the possible operating conditions or installations alternatives. Special loads imposed during erection should be recognised;
- information concerning material and components;
- main dimensions and cross section values of all load bearing structural components;

- determination of the most unfavourable stresses and details relating to the strength of the load bearing structural components and of the fasteners. If calculation seems not sufficient to evaluate limit states of assemblies the analysis may be substituted by testing at an independent testing body. There, the testing body shall commit the appropriate number of tests, samples, the testing procedure, the reporting etc., according to the relevant EN standards or, in absence, to agreements by parts;
- details of elastic deformations (flexure, torsion), in as much as such details affect the serviceability or operating safety of the tent;
- details of those components which require special examination and inspection.

5.2 Selection of textile materials

5.2.1 General

All materials shall comply with EN standards, if EN standards are not available, the suitability of these materials shall be proved by other means (i.e. by International Standards or tests). Where structural joints are to be welded, the designer shall give special consideration in accordance with EN standards to the weldability of the selected material.

The main characteristics of fabric shall be defined and proved by test regarding the following specifications:

- nature of textile and coating;
- total weight;
- tensile strength at 23 °C (average and characteristics values) and at 70 °C (average values);
- tear strength;
- adhesion;
- burning behaviour.

The supplier certification shall be proved for polyester and polyvinylchloride fabrics. After five years tensile strength shall be not less than 70 % of initial value. This value has to be attested by the manufacturer of the fabric.

For the fabrics materials and cladding elements as:

- cotton fabrics;
- synthetic fabrics;
- solid covering and sheeting such as sectional metal sheets, wood or plastic panels and multi components elements.

The following requirements shall be regarded:

- fabric materials designated for structural use shall conform to EN standards or, in absence, to agreement by parts;
- it shall be ensured that the material and the connections specified provides sufficient leaking strength, tear strength to ensure safe and durable performance of the textile cover. The safety factors for structural use of fabrics shall be according to 7.6;
- standards for textile, membrane and inflatable structures.

The applicable standards dealing with burning behaviour are listed in Annex A.

EN 13782:2005 (E)**5.2.2 Connections of fabrics**

Connections by sewing, welding and adhesives and zips shall conform to standards or shall be tested for their ultimate tear and shear properties. The ageing and environmental influences shall be taken into account by the application of additional safety factors.

Zips shall be tested for their strength to withstand the calculated loads of the structure. Effects of wearing out and influence of UV light on plastic shall be considered.

If suitable structural strength cannot be verified they can only be used in non-safety critical applications. Those for emergency exits shall be easy to use from both sides.

6 Design actions**6.1 General**

All the applicable actions shall be taken into account according to EN 1991-1-1, EN 1991-1-2, EN 1991-1-3 and EN 1991-1-4.

Adaptations due to the special utilisation of tents are stated in the following chapters.

6.2 Permanent actions

For tents a very precise assumption of the permanent actions is possible. As far as variation can occur the values G_{ku} and G_{ki} shall be taken into account for assessing the applicable structural response. Elsewhere a single characteristic value G_k is sufficient:

G_k : characteristic value of permanent action;

G_{ku} : upper characteristic value;

G_{ki} : lower characteristic value.

Included in the above category are the actual dead load of the load bearing structure, of the accessories and of the technical equipment required for operation also the claddings, decoration and the like. The influence of dry or wet material conditions shall be recognised (G_{ku} , G_{ki}).

The permanent actions shall be determined according to EN 1991-1-1, EN 1991-1-2, EN 1991-1-3 and EN 1991-1-4.

6.3 Conventional load

The stability shall be checked with a conventional vertical load of $0,1 \text{ kN/m}^2$. This load shall not be combined with other load cases, except self-weight.

6.4 Variable actions**6.4.1 Life loads****6.4.1.1 Universal, public access**

$$\rho = 3,5 \text{ kN/m}^2$$

for floors, stairways, landings, ramps, entrances, exits and the like in facilities (tents, booths).

$$\rho = 5,0 \text{ kN/m}$$

for raised platforms or if particularly dense crowds are anticipated for the above mentioned category.

$$\rho = 1 \text{ kN per step}$$

for stairs, alternatively, an area load in accordance with clauses above, whatever is more unfavourable.

$$\rho = 1,5 \text{ kN/m}^2$$

for seat boards of rows of seats per seat run and for floors between fixed rows of seats, unless higher loads results from the application of area loads ($\rho = 3,5 \text{ kN/m}^2$).

6.4.1.2 Not open for public access

$$\rho = 1,5 \text{ kN/m}^2$$

for all floors, platforms, ramps, staircases, catwalks and the like which are walked over by individual persons or 1,5 kN individual load, whatever is more unfavourable.

6.4.1.3 Horizontal imposed loads

The following horizontal imposed loads shall be applied for parapets, fences, railings, wall panels etc.

When bounding floors with public access designed for $\rho = 3,5 \text{ kN/m}^2$:

- 0,5 kN/m at hand rail height;
- 0,1 kN/m at intermediate rail height.

When bounding floors with public access designed for $\rho = 5,0 \text{ kN/m}^2$:

- 1 kN/m at hand rail height;
- 0,15 kN/m at intermediate rail height.

When bounding floors without public access designed for $p = 1,50 \text{ kN/ m}^2$:

- 0,30 kN/m at hand rail height;
- 0,10 kN/m at intermediate rail height.

For horizontal load acting at floor level take 1/10 of vertical load.

6.4.2 Wind loads

6.4.2.1 General

The wind loads shall be based on EN 1991-1-4, assuming that the special nature of the textile covers are taken into account and regarding:

- location;
- duration and period of installation;
- use under supervision of an operator;
- possibilities of protecting and strengthening.

EN 13782:2005 (E)**6.4.2.2 Following minimum loads shall be applied:**

For any other location where $v_{ref} > 28$ m/s, calculations shall be provided for the tent verifying the stability and resistance with the local conditions. Special measures have to be taken. In the design calculations the necessary means shall be verified through calculation.

For $v_{ref} \leq 28$ m/s, the wind load per unit may be evaluated applying the following minimum values given in EN 1991-1-4 with:

$$c_{TEM} = 0,8$$

$$T_r = 10 \text{ years}$$

$$c_d = 1$$

$$c_{ALT} = 1$$

Table 1 — Wind loads

height: h m	pressure: q N/m ²
$h \leq 5$	500
$5 < h \leq 10$	600
$10 < h \leq 15$	660
$15 < h < 20$	710
$20 < h \leq 25$	760

As simplification, the values given in Table 1 may be applied with the distribution shown in Figure 1.

Contrary to the pressures specified in Table 1, a reduced pressure of 300 N/m² may be applied in the case of tents with a width of 10 m or less and height of 5 m or less.

The aerodynamic coefficients for closed tents of cylindrical shape are presented in Annex B.

Dimensions in metres

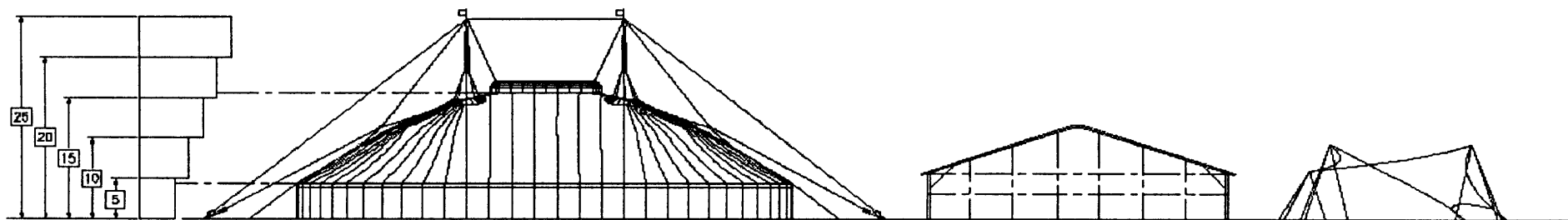
**Figure 1 – Application of wind loads**

In general the shape factors for various structures and structural members shall be taken from EN 1991-1-4. However on the basis of past experience with structures of conventional design, the shape factor for structures on the type illustrated in Figure 2 or similar may be determined with the aid of the factors given there.

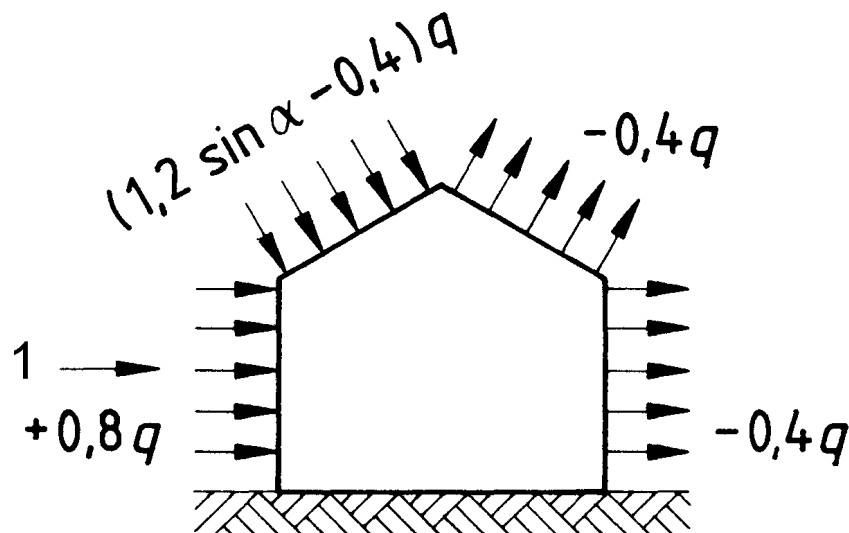
**Key**

1 Direction of wind

Figure 2 — Aerodynamic coefficients for structures of conventional shape**6.4.2.3 Wind on the membrane load bearing structure**

The shape coefficients may be taken according to EN 1991-1-4, or to wind tunnel test.

Wind tunnel testing shall be done by an experienced laboratory in accordance with the relevant Part of Eurocode 1.

Wind coefficients are presented in Figure 3.

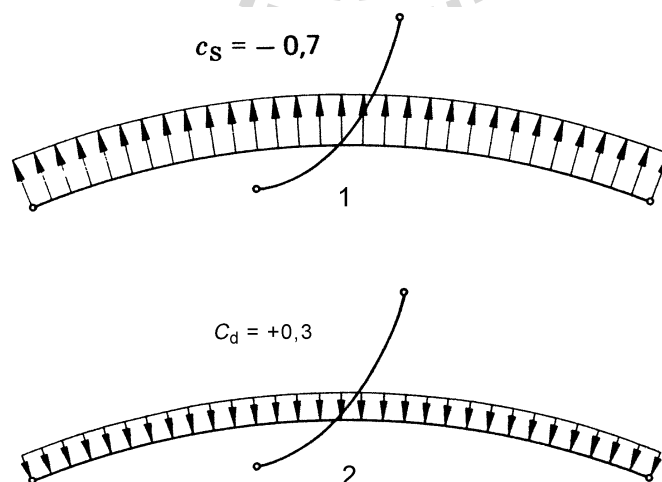
**Key**

- 1 Wind up
- 2 Wind down

Figure 3 — Wind coefficients

These values can be applied to closed structures.

6.4.3 Snow loads

6.4.3.1 General

Snow loads shall be applied in accordance with EN 1991-1-3.

Special conditions concerning snow loads shall be stated in the Tent book.

6.4.3.2 Snow loads

Snow loads need not to be taken into account for tents:

- erected in areas, where there is no likelihood of snow or;
- operated at a time of the year, where the likelihood of snow can be discounted or;
- where by design or operating conditions snow settling on the tent is prevented;
- where pre-planned operation action prevents snow settling on the tent.

This last condition may be achieved by:

- sufficient heating equipment is installed and is ready for use and;
- heating is started prior to snow fall and;
- tent is heated in such a way, that the whole roof cladding has an outside air temperature of more than + 2 °C;
- cladding is made and tensioned in such a way, that pounding of water or any other deformations of the cladding cannot take place.

6.4.3.3 Reduced snow loads

Reduced snow loads for tents, may be applied with 0,2 kN/m² on the overall roof area, provided that a snow height not exceeding $h = 8$ cm can be assured at any time by removing snow.

6.5 Seismic forces

Seismic forces may generally not be considered because of the flexibility and the light weight of the tent.

6.6 Load combinations

Load combinations shall be applied in accordance with EN 1991-1-1.

6.6.1 General

Limit states assessment for tents shall be calculated with the following combinations and partial safety factors.

6.6.2 Fundamental combinations

The design values of the actions shall be combined in the following way:

$$\gamma_G G_k + \gamma_F Q_{k,1}$$

$$\gamma_G G_k + \sum \gamma_F Q_{k,i}$$

EN 13782:2005 (E)

All cases shall be checked, where

$\gamma_G = 1,35$ partial safety factor for unfavourable permanent actions;

$\gamma_G = 1,0$ partial safety factor for favourable permanent actions;

$\gamma_F = 1,5$ partial safety factor for only one variable action;

$\gamma_F = 1,35$ partial safety factor for more variable actions;

G_k characteristic value of permanent action;

$Q_{k,i}$ characteristic value of one of the variable actions.

7 Verification of stability and equilibrium

7.1 General

The limit states due to all different actions shall be determined separately for the individual actions of Clause 6. The limit states due to the combinations of actions shall be calculated. It shall be verified that the design value of internal forces or moments does not exceed the corresponding design resistance of the respective part and the ultimate or serviceability limit state is not exceeded.

Special consideration shall be given to the limit state verification regarding deformation and stability, as the deformation limit can be a decisive value. Any favourable effect resulting from the 2nd order theory may be taken into account.

All verifications shall be performed for the most unfavourable loading. In this connection, the permanent, variable and accidental actions shall always be assumed to have the position and magnitude which result in the most unfavourable limit states for the structural and mechanical components to be calculated. For structural and mechanical components and items of equipment which are not permanent fixtures, it shall also be ascertained whether more unfavourable conditions are likely to arise when such items are displaced or removed.

Non-standard equations shall be recorded in writing with the symbols in accordance with European Standards or International Standards. The sources of such equations shall be stated, if this source is accessible to everyone. In other cases, the derivation of the equations shall be presented to such an extent that their correctness can be verified.

If computer processing for calculation is used, special consideration shall be given to the requirements for the review of computer calculations during the design approval. Clear information concerning the software, equations, units etc. shall be submitted. Input and output shall be completely printed. The correctness of the input assumptions and the output shall be comprehensively reviewed during design approval.

Design resistance shall be evaluated in accordance with the following equation:

$$R_d = \frac{R_k}{\gamma_M} \quad (1)$$

where

R_d is the design value of material properties;

R_k is the characteristic value of material properties;

$\gamma_M = 1,1$ is the partial safety factor for material property in static load combinations for steel.

For materials other than steel the values stated in the respective European Standard shall be taken into account.

7.2 Verification against overturning, sliding and lifting

Safety against overturning, sliding and lifting shall be calculated.

Favourably acting permanent actions shall be taken into account with their lower value only.

If sufficient safety cannot be guaranteed by virtue of the dead load of a structure alone, then further additional steps shall be taken to ensure it, such as counterweights, anchorages and buttresses for example.

As the weight of tents can be determined precisely, the following safety factors are more exact.

Table 2 — Safety factor against overturning, sliding and lifting

Loading		γ
1	Favourably acting proportions of the dead load	1
2	Unfavourably acting proportions of the dead load	1,1
3	Unfavourably acting wind loads	1,2
4	Unfavourably acting proportions of loads other than the loads listed in items 2 and 3	1,3
NOTE If loads are resolved into components, then these components should be multiplied by the same value of γ .		

— The safety against overturning shall be calculated from:

$$\sum \gamma M_{ST,k} \geq \sum \gamma M_{K,k} \quad (2)$$

where

γ is the safety factor in accordance with Table 2;

$M_{ST,k}$ are the stabilising moment proportions (service load);

$M_{K,k}$ are the overturning moment proportions (service load).

Care shall be taken to ensure that the loads entered in the calculation are capable of being activated over the stiffness of the structure.

— The safety against sliding shall be calculated from

$$\sum \gamma \mu N \geq \sum \gamma H \quad (3)$$

where

γ is the safety factor in accordance with Table 2;

N is the vertical load component (service load);

H is the horizontal load component (service load);

μ is the coefficient of friction in accordance with Table 3.

EN 13782:2005 (E)

The following coefficients of friction may be assumed for the determination of the frictional forces, unless higher values determined by tests are available in individual cases, or unless moisture dictates the adoption of lower values.

Table 3 — Coefficients of friction

	Wood	Steel	Concrete
Wood	0,4	0,4	0,6
Steel	0,4	0,1	0,2
Concrete	0,6	0,2	0,5
Clay ^a	0,25	0,2	0,25
Loam ^a	0,4	0,2	0,4
Sand and gravel	0,65	0,2	0,65

^a At least of stiff consistency in accordance with ENV 1997-1.

It shall be borne in mind that loosening by vibration may occur in the case of supports subjected to vibratory stress. If stability is not attained by static friction alone then the structure should be anchored in the ground. In such cases the safety against sliding shall be calculated in conjunction with the action of soil anchors. In this context, the coefficients of friction in accordance with Table 3 shall only be entered in the calculation at 70 % of the listed values.

$$\sum \gamma \mu N + Z_{d,h} \geq \sum \gamma H_k \quad (4)$$

where

$Z_{d,h}$ is the horizontal design value of the anchor.

The safety against lifting shall be calculated from:

$$\sum \gamma N_{ST,k} \geq \sum \gamma N_{m,k} \quad (5)$$

where

$N_{ST,k}$ are the vertical stabilising load components (service load);

$N_{m,k}$ are the vertical lifting load components (service load).

With anchor ties we have the following relationship

$$\sum \gamma N_{ST,k} + Z_{d,v} \geq \sum \gamma N_{m,k} \quad (6)$$

where

$Z_{d,v}$ is the vertical design value of the anchor.

7.3 Dead load for tent covers

The dead load of dry canvas shall be assumed as being 5 N/m^2 for the calculation of the structures in respect of wind pressure from below which is required for the assessment of the safety against overturning and for the sizing of the anchoring; for all other purposes, it shall be assumed as specified in EN standards or, in absence, in agreement by parts.

7.4 Structures with primary load bearing structure (i.e. roof, truss, tents)

7.4.1 Ballast mountings for protection against wind suction loads

Permanent mountings (furniture in the tents) for the absorption of forces may be included in the calculation, on condition that they will be activated without any doubt. For anchor loads etc. see also 8.3.

7.4.2 Wind bracings

The wind bracings arranged in the roof and wall plain shall be capable of absorbing the forces acting on the gables. Two wind bracings may be arranged in consecutive bays in such a way that each is designed to absorb one half of the forces acting on the gable. The intermediate bracings shall be designed for half of the forces acting on the gable. Intermediate bracings shall also be provided for those structures, where gable forces do not occur. Generally a maximum of six bays, not exceeding 30 m, free of bracings may be situated between the bracings. If not, a special calculation shall be carried out.

In braced bay all forces arising in the main frame due to the bracing shall be considered, including the forces required to provide stability. The main frame members (forces for the stabilisation of the roof trusses etc.) shall also be taken into account in the sizing of the bracings.

In case of pitch roofs, where in the bracing area deflection forces arise from the angle of the frame girders at the ridge, these forces shall be taken into account.

7.4.3 Cladding forces on the structure due to wind

Wind acting on the flexible claddings generates one-sided traction forces particularly in the end bays. These forces shall be considered at all rim-supports (i.e. ridge, eave purlins, rafters, corner-up-rights).

The value of the traction forces depends on various parameters (i.e. geometry, cut sizes, joints, material properties, climate influences). These forces shall be approximately evaluated by iterative calculation taking into account the stiffness of the material and the tolerances of fabrication.

The membrane forces resulting from wind may be taken as $0,8 \text{ kN/m}$ if no exact verification is carried out. This applies to 5 m span and a wind load of $q = 0,5 \text{ kN/m}^2$. For other spans and wind loads a conversion may be done using a constant ratio sag / span ($f/l = \text{const.}$)

The absorption of these membrane forces by all the edge girders (ridge purlins, eaves purlins, roof truss girders and corner posts) shall be checked.

The increased edge suction loads (according to wind load standards for buildings) can be ignored for flexible wall and roof surfaces. As regards right roof coverings, the fastening means shall be sized in accordance with EN standard or, in absence, agreements by parts in respect of the increased edge suction loads.

7.5 Membrane

7.5.1 General

If the shape of the structure allows a calculation in two opposite directions separately, the calculation may be hand made. In any other case an appropriate three dimensional computer calculation taking into account great displacement shall be used.

EN 13782:2005 (E)

In cases where non linear deformation can lead to favourable load carrying effects on certain elements, the safety coefficients shall be applied not on load side but on the material side.

Because a failure of the load bearing membrane can lead to a complete collapse of the entire structure, the suitability of the material and of the jointing and fastening techniques shall be demonstrated by approval or other certificates according to EN standards or, in absence, to agreement by parts.

7.5.2 Pre-stressing

The structure shall be mechanically pre-stressed in order to stabilise the membrane structure against the external loads which arise, and also in order to prevent any whip, flutter or breakdown.

The permanent working load of the membrane at the edge of the structure resulting from pre-stressing shall not exceed 5 % of the short duration average tensile strength of the fabric. More may be taken into account with justification by tests.

Actions (pre-stressing, snow load and wind load) shall be combined to take into account the non-linear behaviour of the structure. The pre-stressing load shall be considered in the load combination with its adequate safety factor.

7.5.3 Design and construction details on membrane

The cutting pattern of the membrane shall be laid in accordance with the calculation.

The line of the breadth should be put in accordance with main direction of the stress.

If rope-, belt- or skin-strengthening is foreseen, care shall be taken that no weakening of the base-material occurs (e.g. by amassment of seams, clamps or eyelets).

7.6 Verification of load bearing capacity of technical textiles and their connections**7.6.1 General**

The following equation is valid for both material and connections:

$$f_d = \frac{f_{tk}}{\gamma_m} \quad (7)$$

where

f_d design resistance (U.L.S.);

f_{tk} characteristic tensile strength in monoaxial tensile short duration tests at 23 °C;

γ_m safety coefficient given in Table 4.

The characteristic values are determined according to EN 1991-1-1.

Coefficients to apply for polyester coated with polyvinylechloride and their welded connections see Table 4.

Characteristic values for both materials and connections shall be evaluated by tests.

If test are not enough to calculate f_{tk} it shall be assumed $f_{tk} = 0,8 f_{tm}$, where f_{tm} is the average of tensile strength in tensile short duration test at 23 °C.

Table 4 — Safety coefficients for material and welded connections HF (PES+PVC)

	Product in conformity with EN 10204:2004, 2.2)	Product in conformity with EN 10204:2004, 3.1
<u>Material</u>		
permanent load	2,5	2,5
short duration loads	2,5	2
in presence of snow	2,5	2
<u>Welded connections 1st class</u>		
permanent load	---	7
short duration loads	---	3
in presence of snow	---	2,5
<u>Welded connections 2nd class</u>		
permanent load	15	12
short duration loads	6	5
in presence of snow	6	5
NOTE		
"Short duration loads" means load conditions with high temperature.		
"In presence of snow" means load conditions without high temperature.		

These values are valid only if test on connection give a value more than 70 % of tensile strength of the material both in tests at 23 °C and 70 °C.

When these criteria are not respected and for other material than PES + PVC more special investigations shall be done regarding the influence of temperature and permanent load.

All tests shall comply with the relevant EN standards or, in absence, with agreement by parts. At least there shall be 3 tests performed to achieve the standard deviation and the 95 % confidence intervals of the main values according to the procedures given in ISO 2602.

7.7 Safety margin, safeguards

Because a load bearing membrane can be subject to considerable deformations, care shall be taken to ensure that no structural or other parts, may hinder the deformation of the membrane if not taken into account in the calculation.

In so far as rigid load bearing components (i.e. masts, supports etc.) are restrained solely by the membrane, the overturning of such components in the event of a one sided removal of the membrane shall be prevented by additional measures, and the necessary degrees of freedom of movement in the operating condition shall remain intact.

For a pole tent with a span greater than 12 m and mast high greater than 7 m, both poles and masts shall be independently guided to prevent or delay their collapse in the event of total or partial membrane failure unless the design can justify otherwise.

7.8 Post tensioning

Design measures which enable a post-tensioning of the structure to be effected should be incorporated (e.g. turnbuckles, support extensions etc.), for the purpose of compensating the creep of the membrane (material, stitching, fastenings, ropes etc.).

8 Ground anchorages

8.1 General

Uncertain soil conditions make it extremely difficult to assess the load bearing capacities of anchorages accurately. If for the respective soil conditions no verification using the rules of foundation engineering is carried out the following approximation method may be used for pre-dimensioning. Any case test shall be realised on each site; for tents up to a span of 10 m testing is not necessary.

This clause is restricted to

- a) weight anchors, i.e. ballast bodies placed on the surface of the ground or buried, and
- b) rod anchors, i.e. metal fitted with eyelets or with an upset head; without further proof they shall not be used for long-term installation.

Concerning special anchors such as wing anchors, folding anchors, screw anchors and sectional steel anchors for example, the determination of their load bearing capacities loading tests shall be done.

8.2 Load bearing capacity of weight anchors

When calculating the load bearing capacity of fully or partially buried anchors, the passive earth pressure shall only be taken into account on condition that the anchor is capable of performing small displacements and rotations without any danger to the structure and that the foundation soil conditions are sufficiently known.

8.3 Load bearing capacity of rod anchors

The load bearing capacity of simple rod anchors with a circular cross section and a minimum driving-in depth of 80 cm shall be determined in accordance with the approximation equations given in Table 5.

Table 5 — Load bearing capacity of rod anchors

Angle of pull	Load bearing capacity <i>N</i>
$\beta = 0$	$Z_d = 6,5 \text{ dl'}$ for stiff cohesive and for dense cohesion less soils
$\beta = 0$	$Z_d = 8 \text{ dl'}$ for very stiff cohesive soils
$\beta \geq 45$	$Z_d = 10 \text{ dl'}$ for cohesive soils of at least medium to stiff consistency
$\beta \geq 45$	$Z_d = 17 \text{ dl'}$ for dense cohesion less soils
$0 < \beta < 45$	The load bearing capacity for the soil types shall be determined by interpolation

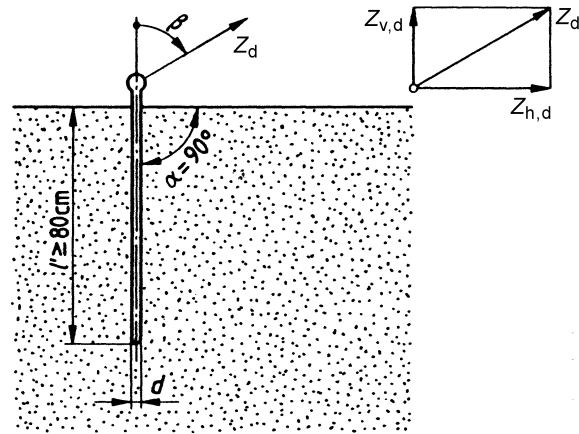
**Key**

- Z_d is the anchor service load (service load), in N;
- $Z_{h,d}$ is the horizontal anchor service load, in N;
- $Z_{v,d}$ is the vertical anchor service load, in N;
- d is the anchor diameter, in cm;
- l' is the depth of penetration in cm;
- α is the angle of penetration;
- β is the angle of acting tensile force to the vertical.

Figure 4 — Rod anchor

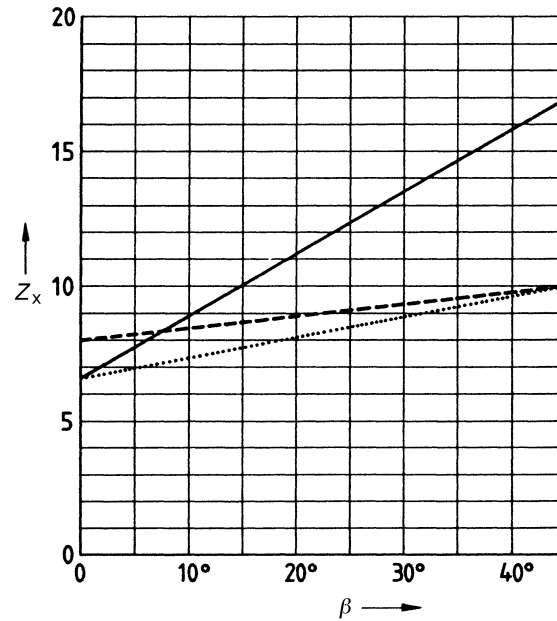
**Key**

- is a dense cohesion less soils;
- is a very stiff cohesive soils;
- is a stiff cohesive soils.

Figure 5 – Factor Z_x for determining the load bearing capacity of rod anchors

The equations given in Table 5 are only valid on the condition that the anchor will "pull" when driven it:

- for $\beta = 0^\circ$ the friction shall be effective along the entire length of the rod;
- for $\beta \geq 45^\circ$, the angle of penetration α shall be 90° .

At this driving-in angle, the obliquely loaded anchor will attain its maximum load bearing capacity, as proved by experience.

In order to prevent any bending of anchors subjected to oblique traction, the following diameter shall be kept for simple round steel rod anchors:

$$d_{\min} = 0,025 l' + 0,5 \text{ (with } l' \text{ in cm)}$$

The point of application of the force on rod anchors subjected to bending stress shall be situated as close to the ground surface as possible, or beneath it.

The end of the rods shall present no increase of section, in order not to decrease the friction at the stem.

A rod anchor is presented in Figure 4.

The factors for determining the load bearing capacity of rod anchors are presented in Figure 5.

8.4 Testing of anchors

A safety factor of $\nu = 1,6$ regarding ultimate limit load is to apply for the lowest test value in order to determine the load bearing capacity in subsequent calculation. The load bearing capacity determined in this manner shall not result in anchor movement which would result in stresses, deformations or instability inadmissible for the structure.

If the foundation conditions are comparable, test loadings carried out in another location may be adduced for substantiation purposes.

9 Other structural components

9.1 Cables, ropes, chains, safety devices

Besides the calculation the load bearing capacity of materials or accessories, which relates directly to the safety of the public shall be verified either by manufacturer conformity certificate or test.

When ropes, chains, safety devices, rope drives, connectors and adapters are used, the following EN standards in particular shall be applied for:

- steel wire ropes (cables) EN 12385, parts 1 to 9;
- chains EN 818;
- spring safety hocks EN 1677, parts 2 and 5.

For the following cases the national standards shall be applied:

- natural fibre ropes;
- synthetic material ropes;
- clamps for wire ropes;
- rope drives;
- eye hocks;
- roller buckles;
- shackles;
- safety harnesses;
- safety ropes;
- turnbuckles.

EN 13782:2005 (E)**9.1.1 Ropes without fittings influence**

For ropes without fittings at ultimate limit state, we have

$$R_d = \frac{R_{\min}}{\gamma_M} \quad (8)$$

where

R_d is the design load;

R_{\min} is the minimum breaking load (certified by manufacture, see EN 12385);

$\gamma_M = 2,0$;

$\gamma_M = 2,0$ for both non linear behaviour or linear behaviour, including a risk of damage for frequent dismantling.

9.1.2 Ropes with fittings influence

For ropes with fittings R_{\min} shall be multiplied by an efficiency factor (depending on the kind of fittings) given in EN standards or, in absence, confirmed by test.

9.1.3 Synthetic fibre ropes

As regard fibre ropes made of synthetic fibres, the values given in Table 6 shall apply depending U.L.S.

Table 6 — Factors for synthetic fibre ropes (according to EN ISO 1141, EN ISO 1346 and EN ISO 1969)

rope diameter mm	Safety factor
12	4
14	3,3
16	3,3
18	2,7
20	2,7
>20	2,7
NOTE	Values to apply to ultimate limit state.

9.2 Accessories

All accessories shall have at minimum the same safety factor as the steel cables

$$\gamma_M = 2$$

Open hooks need not to be used in bracing's. Hooks with a safety catch are not considered to be open hooks.

9.3 Ratchets

For streps with ratchets, the safety factor of $\gamma_M = 2,0$ shall be applied on the complete system tested regarding ultimate limit loads. Ratchets shall be secured against accidental opening.

9.4 Detail connections

A certificate of conformity for standardised detail connections shall be provided.

For non-standardised detail connections the resistance shall be proved by tests.

The safety factor shall be $\gamma_M = 2,0$.

10 Special design and manufacture criteria

Special design and manufacture criteria are presented in the informative Annex C.

11 Manufacture and supply

11.1 General

Suitably competent persons shall be engaged in the manufacture of tents. Constant attention shall be paid to the inspection of components and raw material, including consumables, both manufacturers in house and subcontracted.

Where design verification or specification has indicated that certain parts are safety critical and has specified certain tests the manufacturer shall ensure that appropriate preparations for initial approval tests are provided. Non-destructive testing (NDT) techniques will be relevant to certain aspects of manufacture, for example welds shall be inspected for quality if they are safety critical components.

The manufacturer shall ensure the specified level of quality for each component of tents and determine the standard of manufacture necessary to achieve this, in accordance with design specification.

EN 13782:2005 (E)**11.2 Certificates**

Certificates on material or components according to EN 10204 shall be done at least for the following items:

- steel, aluminium and timber for load bearing members;
- standardised components, if there is no agreed or general method of calculation;
- burning behaviour.

Hooks, safety hooks, shackles, turnbuckles or other accessories shall be considered as certified, if they are marked by the manufacturers according to existing standards.

If necessary, correction of the design resistance shall be done according to the specific use.

Ropes, chains etc. shall be supplied with certificate showing the guaranteed minimum breaking load.

11.3 Observation of the design specification

The manufacturer shall ensure that the design specification is fully incorporated into the completed tent and that the quality of the use materials and the manufacture procedure meet the design specification.

This shall be confirmed by an inspection.

11.4 Description of installation and operation procedures

The description of installation and operation procedures shall give information concerning:

- type of tents, the main design characteristics, possible varying installations, the main dimensions, the dimensions of exits and entrances, the working and operating process;
- installation and operation of the tents;
- safety devices which are or become effective in exceptional situations (i.e. instructions concerning snow, wind, anchorage and fire).

12 Examination**12.1 General**

Tents have to be inspected.

12.2 Qualification

The following experts during the design with relevant experience in the field of tents shall be available if appropriate:

- civil engineers (calculation, design);
- electrical experts (safety of electrical systems);
- weld engineers (weld and material approval);
- material and test engineers (laboratory examination, non-destructive test methods).

12.3 Competence

The following laboratory and testing facilities shall be made available:

- material testing machines (tensile, notched impact, pulsator testing machines);
- non-destructive testing facilities (ultrasonic, surface crack, X-ray inspection).

13 Procedures for approval, examination and tests

13.1 General

As a general rule all safety relevant design documents as well as the completed tent shall be subjected to review and inspection. Manufacturers and inspection bodies shall be independent of each other.

The relevant certificate shall be only granted after a successful examination. The results of the various examinations shall become an integral part of the tent book.

The following tests have to be performed:

- A: Initial approval of tent;
- B: Periodic thorough examination;
- C: Examination after modification, repair and accidents, see different steps of A;
- D: Installation examination.

13.2 Identification

All relevant documents of tents shall be identified as follows:

- reference to this European Standard (i.e. EN 13782);
- country;
- name of manufacturer;
- year of production;
- technical identification;
- number of batch;
- burning behaviour.

13.3 Initial approval of tents

13.3.1 General

Each tent shall be subject to an initial approval, this shall comprise of:

- design review;
- inspection of construction work.

EN 13782:2005 (E)**13.3.2 Review of design and construction documents**

The design documents shall be reviewed and checked; this has to be certified:

- completeness;
- correctness of all the assumptions with respect to the input values for the static analysis;
- correctness of the design calculation of all load bearing components, their connections and joints;
- compliance with the present standard.

13.3.3 Inspection of construction work

The inspection of the construction work shall be carried out at the manufacturer or at the first installation of the tent respectively. It shall be checked and certified:

- conformity with the approved technical specification (main dimensions of the tent, dimensions of the components including their connections and joints, material used, corrosion protection);
- manufacturing process (if appropriate);
- correct execution of welds;
- existence of necessary verifications and certificates concerning material properties, fire protection, welding etc.

13.4 Inspection after repair, modification and accidents

The tent and associated parts shall be subject to a further examination before being taken back into use following any repair, any modification or any alteration likely to have affected the integrity of the tent.

13.5 Report

The result of the initial approval, the examination after modification, the periodic thorough examination and the installation examination shall be recorded.

14 Tent book**14.1 General**

The tent book associated with the tent shall include the design documents which provide detailed information with respect to operating data, method of construction, instruction relating to operation and maintenance, repairs and modifications as well as to examinations.

The tent book shall be available as a document on each erection site for evidence.

14.2 Content

The tent book shall comprise especially the following documents:

- design and operation descriptions;
- general design drawings (clear presentation of the entire facility, i.e. on a 1 : 100 or 1 : 50 scale);
- detail drawings (accurate illustrations of the structural components and their connections, i.e. on a 1 : 10 or 1:5 scale; other scales are possible only if clearness is not reduced);

- static analysis;
- reports according to 13.7 as well as reports on any other inspections, if applicable;
- instructions written in the language of the user and the country of destination (at least either in German, English or French) covering erection and dismantling, maintenance, list of all parts requiring periodic replacement.

15 Use and operation

Recommendations for use and operation are presented in the informative Annex D.



Annex A (informative)

Burning behaviour

Identification of national standards about the burning behaviour of textile fabrics (for the covering of temporary structures) in CEN member-countries

Walls, fabrics used for textile decorations and other materials (except planed wood with a thickness of more than 20 mm) should have a permanent flame retardance.

No national standard reference was identified in the following countries:

AUSTRIA – CYPRUS – CZECH REPUBLIC – DENMARK – ESTONIA – FINLAND – GREECE – HUNGARIA – IRLAND – ISLAND – LATVIA – LITHUANIA – LUXEMBOURG – MALTA – NETHERLANDS – NORWAY – POLAND – PORTUGAL – SLOVAKIA – SLOVENIA – SWEDEN – SWITZERLAND

EUROPEAN STANDARDS

EN 1101:1996, *Textiles and textile products — Burning behaviour — Curtains and drapes — Detailed procedure to determine the ignitability of vertically oriented specimens (small flame)*

EN 1102:1995, *Textiles and textile products — Burning behaviour — Curtains and drapes — Detailed procedure to determine the flame spread of vertically oriented specimens*

EN 1624:1999, *Textiles and textile products — Burning behaviour of industrial and technical textiles - Procedure to determine the flame spread of vertically oriented specimens*

EN 1625:1999, *Textiles and textile products — Burning behaviour of industrial and technical textiles — Procedure to determine the ignitability of vertically oriented specimens*

EN 1363-1, *Fire resistance tests — Part 1: General requirements*

EN 1363-2, *Fire resistance tests — Part 2: Alternative and additional procedures*

EN 1364-1, *Fire resistance tests for non-loadbearing elements — Part 1: Walls*

EN 1364-2, *Fire resistance tests for non-loadbearing elements — Part 2: Ceilings*

EN 1365-1, *Fire resistance tests for loadbearing elements — Part 1: Walls*

EN 1365-2, *Fire resistance tests for loadbearing elements — Part 2: Floors and roofs*

EN 1365-3, *Fire resistance tests for loadbearing elements — Part 3: Beams*

EN 1365-4, *Fire resistance tests for loadbearing elements — Part 4: Columns*

EN 1365-5, *Fire resistance tests for loadbearing elements — Part 5: Balconies and walkways*

EN 1365-6, *Fire resistance tests for loadbearing elements — Part 6: Stairs*

EN 13501-1, *Fire classification of construction products and building elements — Part 1: Classification using test data from reaction to fire tests*

EN 13501-2, *Fire classification of construction products and building elements — Part 2: Classification using data from fire resistance tests, excluding ventilation services*

EN 13238, *Reaction to fire tests for building products — Conditioning procedures and general rules for selection of substrates*

EN 13772, *Textiles and textile products — Burning behaviour — Curtains and drapes — Measurement of flame spread of vertically oriented specimens with large ignition source*

EN 13773, *Textiles and textile products — Burning behaviour — Curtains and drapes — Classification scheme*

EN 13823, *Reaction to fire tests for building products — Building products excluding floorings exposed to the thermal attack by a single burning item*

EN 14115:2001, *Textiles — Burning behaviour of materials for marquees, large tents and related products — Ease of ignition*

EN ISO 1182, *Reaction to fire tests for building products — Non-combustibility test (ISO 1182:2002)*

EN ISO 1716, *Reaction to fire tests for building products — Determination of the heat of combustion (ISO 1716:2002)*

EN ISO 6941:2004, *Textile fabrics — Burning behaviour — Measurement of flame spread properties of vertically oriented specimens*

EN ISO 6940, *Textile fabrics — Burning behaviour — Determination of ease of ignition of vertically oriented specimens (ISO 6940:2004)*

EN ISO 9239-1, *Reaction to fire tests for floorings — Part 1: Determination of the burning behaviour using a radiant heat source (ISO 9239-1:2002)*

EN ISO 11925-2, *Reaction to fire tests — Ignitability of building products subjected to direct impingement of flame — Part 2: Single-flame source test (ISO 11925-2:2002)*

NATIONAL STANDARDS

BELGIUM

NBN G 50-002:1986, *Textiles — Burning behaviour of textiles and textile products — Vocabulary*

FRANCE

NF P 92-507:2004, *Safety against fire — Building — Interior fitting materials — Classification according to their reaction to fire*

NF P 92-503:1995, *Safety against fire — Building materials — Reaction to fire tests — Electrical burner test used for flexible materials*

FD G 07-180:1985, *Textiles — Fire behaviour — Data for choosing standardized methods of test to be used*

NF G 07-182:1985, *Textiles — Fire behaviour — Measurement of flame spread properties of 45 degrees oriented specimens - Determination of flame spread rate*

NF G 07-184:1985, *Textiles — Behaviour in fire — Classification method based on the surface destroyed*

EN 13782:2005 (E)**GERMANY**

DIN 4102-1:1998, *Fire behaviour of building materials and building components — Part 1: Building materials, concepts, requirements and tests*

DIN 4102-2:1977, *Fire behaviour of building materials and building components — Components — Definitions, requirements and tests*

DIN 18204-1:2003, *Components for enclosures made of textile fabrics and plastic films (awnings) for structures and tents — Part 1: PVC coated polyester base fabrics*

DIN 54333-1:1981, *Testing of textiles — Determination of burning behaviour — Horizontal method — Ignition at the edge of the specimen*

DIN 54334:1975, *Testing of textiles — Determination of the burning behaviour — Minimum ignition time, edge ignition*

DIN 54335:1977, *Testing of textiles — Determination of burning behaviour, 45°-method, ignition on the edge of the specimen*

DIN 66080:1988, *Classification of burning behaviour of textile products — Principles*

ITALY

UNI 8456, *Combustible materials which can be hit by flame on both surfaces. Reaction to fire by applying a small flame*

UNI 8457, *Combustible materials which can be hit by flame on one surface. Reaction to fire by applying a small flame*

UNI 9174, *Reaction to fire of material can be hit by flame with radiant heating*

UNI 9176, *Reaction of fire. Preparation of materials for verification of requirements*

UNI 9177, *Reaction to fire. Combustible materials classification*

SPAIN

UNE 23727:1990, *Reaction to fire tests of building materials — Classification of building materials*

UNE 23723:1990, *Reaction to fire tests of building materials — Electrical burner test used for flexible materials 5 mm thick or less*

UNE 40466-2:1983, *Heavy cloths — Fire behaviour — Vertical test method*

UNITED KINGDOM

BS 7837:1996, *Specification for flammability performance for textiles used in the construction of marquees and similar textile structures*

BS 5438:1989, *Methods of test for flammability of textile fabrics when subjected to a small igniting flame applied to the face or bottom edge of vertically oriented specimens*

BS 7157:1989, *Method of test for ignitability of fabrics used in the construction of large tented structures*

BS 4790:1987, *Method for determination of the effects of a small source of ignition on textile floor coverings (hot metal nut method)*

BS 5867-1:2004, *Specification for fabrics for curtains and drapes — General requirements*

BS 5867-2:1980, *Specification for fabrics for curtains and drapes — Flammability requirements*



Annex B (informative)

Aerodynamic coefficients for round shape tents

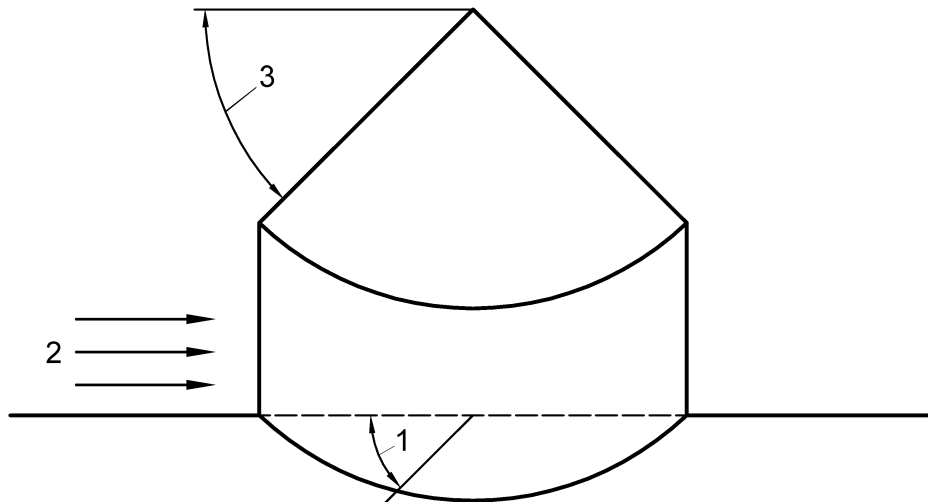

Key

- 1 Angle
- 2 Wind speed
- 3 45° or 22°

Figure B.1 — Round shape tent

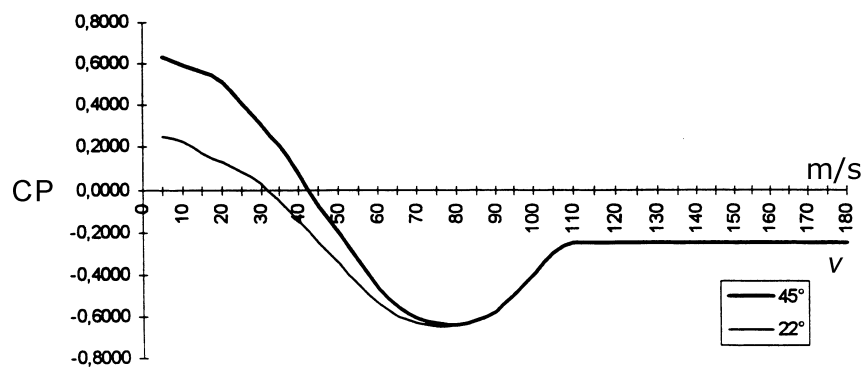

Figure B.2 — Aerodynamic coefficients for round shape tents

Annex C (informative)

Special design and manufacture criteria

C.1 Access to and egress from enclosures, shows and others

Emergency exits should have a height of at least 2,0 m.

No exit should be less than 1 m wide.

The minimum internal headroom should be 2,3 m for frame elements and 2 m for textile element.

The average clear height of tents should be not less than 2,5 m.

C.2 Burning behaviour

Walls, fabrics used for textile decorations and all other materials (except planed wood with a thickness of more than 20 mm) should have a permanent flame retardance. Materials used for roofs at 2,3 m height or higher need not to be permanently flame retardant. Safety cables of pole structures should be made of non-inflammable materials.

C.3 Connection and weldings

C.3.1 General

When manufacturing the load bearing structure the appropriate European Standards for execution, controlling and documentation should be observed (i.e. ENV 1090-1 and ENV 1999-1). According to their design documents textile fabrics should be ready-made in such a way that the forces acting on them are absorbed and transferred safely; this includes that the dimensions are met and that the serviceability is assured.

C.3.2 Welded joints in steel and aluminium structures

The manufacture should meet the requirements of EN 729-3.

Welding supervision personnel should have at least basic technical knowledge as specified in EN 719.

Welding procedures should be approved in accordance with EN ISO 15607, EN ISO 15609-1, EN ISO 15614-1, and EN ISO 15614-2; in case of fully mechanised and automatic procedures for steel and for materials with $R_e > 360 \text{ N/mm}^2$ the approval should be in accordance with EN ISO 15607, EN ISO 15609-1, EN ISO 15614-1, and EN ISO 15614-2. For aluminium the approval should be in accordance with EN ISO 15614-2 regardless of the degree of mechanisation and the material group.

The welders should have the required welders' test certificates as specified in EN 287-1 for steel structures and EN 287-2 for aluminium structures.

The operators should have valid test certificates as specified in EN 1418.

The quality of components should be at least of quality level C as specified in EN ISO 5817 for steel and ISO 10042 for aluminium.

EN 13782:2005 (E)**C.3.3 Textile connection**

Common textile connections are:

- mechanic type (seam, elastic ropes, hooks, plates, zips, stichings);
- chemical - physical type (welding, gluing);
- or mixed.

It is possible to realise connections in other way clearly characterised and defined as after specified.

The connection's classes are three:

- 1st class: connections performed from qualified manufacturer using methodologies defined (that characterise all the parameters and work conditions) from the coated fabric manufacturer or from the membrane assembler and continuously tested, to calculate f_{tk} according to EN 1991-1-1;
- 2nd class: connections performed from qualified personnel using methodologies defined (that characterise all the parameters and work conditions) from the coated fabric manufacturer or from the membrane assembler and initially tested and repeatability checked by visual peeling test;
- 3th class: connections anyway performed, permitted exclusively for the realisation of secondary elements whose failure will not create unfavourable load cases or effects reducing the safety of the tent or of plugging.

In the design the connection class should be chosen in accordance with the structure type.

For tents with primary load bearing structure textile connection can be of 1st or 2nd class.

For membrane tents, the connection should be of 1st class.

The test results and the related test specimen should be filed together with all information allowing reproduction. The files should be retained for 5 years.

The national standards dealing with burning behaviour applied for tents are mentioned in Annex A.

Annex D (informative)

Use and operation

D.1 Periodic thorough examination

Each tent should be examined prior to the end of a period given in the tent book.

The period between two thorough examinations should be done according to local regulation but should not be longer than 3 years.

In general the examination should be carried out on the erected tent. Exceptionally there can be the possibility to check the tent being dismantled.

Mainly the following checks should be performed:

- correct erection;
- check of the structure, especially of modified, repaired or exchanged parts;
- identification of damages, tearing and corrosion;
- check of safety devices (if appropriate);
- fulfilment of conditions from previous examinations.

D.2 Installation examination

D.2.1 General

Tents should be subjected to an installation examination after each new installation, carried out by competent experts.

D.2.2 Extent of installation examination

The following procedure should be performed:

- observance of the conditions imposed by the tent book and their fulfilment;
- correct packing and anchoring according to the plans with respect to the local ground conditions;
- checking of anchorage;
- conformity with the construction documents, existence of all essential load-bearing components inclusive of bracing comparison of forms and cross-sections of load-carrying components. Attention is to be paid to the correct incorporation, staircases, platforms, linings, decorations and similar equipment;
- suitability of the site of tent;
- state of conservation of the essential load-bearing construction parts (random check on site);
- fastening.

EN 13782:2005 (E)**D.3 Escape routes****D.3.1 Common recommendations**

In relation to the number of occupants tents should have at least two favourable situated exits leading in the open having at least a width of 1,0 m and a height of 2,0 m. The exits should be marked as emergency exits. At least one exit should be suitable for wheel chairs.

Calculating the width of the escape routes 1,0 m should be taken for any 150 persons dependent. Interpolation is allowed. The minimum clear width should be 1,0 m.

Without proof of the seats the number of occupants of a tent should be calculated as follows:

- 2 people / m² if seated;
- 3,5 people / m² if standing;

Areas not provided to visitors can be neglected.

D.3.2 Design of emergency exits

An emergency exit should be an exit on an escape route.

Doors should open in the clearing direction and they should be signalled with white symbols on a green sign. The installation of doors in emergency exits should not weaken the load bearing structure of the tent.

When there are no doors, the frames of the exits should be signalled inside as well as outside with green strips having a minimum width of 20 cm. Alternatively other colour contrasting with the colour of the cloth can be used.

The pieces of cloth that close exits can be lowered but if necessary it should be easy to open the exits with a simple and an easy operation.

Emergency exits should be visibly signalled night and day, and inside as well as outside.

D.3.3 Layout of escape routes

The maximum distance from each seat or place to reach an exit leading in the open should be not more than 35 m unless more special measures (i.e. subdivision in fire lobbies) are taken to vacate the people.

The maximum distance from a seat or place to an escape route should not be more than 5 m.

The clear space between two rows of seats should be at least 0,45 m.

D.4 Stairs

Stairs which are used by the public should be at least 1 m in width.

All components should be in conformity with the relevant EN standards or, in absence, with the agreement by parts.

D.5 Heating and cooking systems

Electrical heating system can be installed in tents.

Other heating system should be put outside at a sufficient distance.

The warm-air generators should be with heat exchangers.

To prepare meals and drinks tents can be equipped with fireplaces in kitchens, these areas should be separated.
The heating system should comply with the relevant EN standards or, in absence, with the agreement by parts.

D.6 Electrical fittings

The electrical fittings should comply with the relevant EN standards or, in absence, with the agreement by parts.

D.7 Fire extinguishers

Types and numbers of extinguishers should be in accordance with EN 3.



Bibliography

- [1] EN 3 (all parts)¹⁾, *Portable fire extinguishers*
- [2] EN 287-1, *Approval testing of welders — Fusion welding — Part 1: Steels*
- [3] EN ISO 15607, *Specification and qualification of welding procedures for metallic materials - General rules (ISO 15607:2003)*
- [4] EN ISO 15609-1, *Specification and qualification of welding procedures for metallic materials - Welding procedure specification - Part 1: Arc welding (ISO 15609-1:2004)*
- [5] EN ISO 15614-1, *Specification and qualification of welding procedures for metallic materials - Welding procedure specification - Part 1: Arc welding (ISO 15609-1:2004)*
- [6] EN ISO 15614-2, *Specification and qualification of welding procedures for metallic materials - Welding procedure test - Part 2: Arc welding of aluminium and its alloys (ISO 15614-2:2005)*
- [7] EN ISO 1141, *Fibre ropes - Polyester - 3-, 4- and 8-strand ropes (ISO 1141:2004)*
- [8] EN ISO 1346, *Fibre ropes - Polypropylene split film, monofilament and multifilament (PP2) and polypropylene high tenacity multifilament (PP3) - 3-, 4- and 8-strand ropes (ISO/FDIS 1346:2004)*
- [9] EN ISO 1969, *Fibre ropes - Polyethylene - 3- and 4-strand ropes (ISO/FDIS 1969:2004)*
- [10] EN 719, *Welding coordination — Tasks and responsibilities*
- [11] EN 729-3, *Quality requirements for welding - Fusion welding of metallic materials — Part 3: Standard quality requirements*
- [12] ENV 1090-1, *Execution of steel structures — Part 1: General rules and rules for buildings*
- [13] EN 1418, *Welding personnel — Approval testing of welding operators for fusion welding and resistance weld setters for fully mechanized and automatic welding of metallic materials*
- [14] ENV 1999-1-1, *Eurocode 9: Design of aluminium structures — Part 1-1: General rules – General rules and rules for buildings*
- [15] EN 60204-1, *Safety of machinery — Electrical equipment of machines — Part 1: General requirements (IEC 60204-1:1997)*
- [16] EN ISO 5817, *Welding — Fusion welded joints in steel, nickel, titanium and their alloys (beam welding excluded) — Quality levels for imperfections (ISO 5817:2003)*
- [17] HD 384.4.41 S2, *Electrical installations of buildings — Part 4: Protection for safety — Chapter 41: Protection against electric shock (IEC 60364-4-41:1992, modified)*
- [18] ISO 209-1, *Wrought aluminium and aluminium alloys — Chemical composition and forms of products - Part 1: Chemical composition*
- [19] ISO 834 (all parts), *Fire resistance tests — Elements of building construction*
- [20] ISO 898-2, *Mechanical properties of fasteners — Part 2: Nuts with specified proof load values — Coarse thread*

1) Parts 8 to 10 to be published.

- [21] ISO 2532, *Steel wire ropes — Vocabulary*
- [22] ISO 3898, *Basis for design of structures — Notations — General symbols*
- [23] ISO 6362-1, *Wrought aluminium and aluminium alloy extruded rods/bars, tubes and profiles — Part 1: Technical conditions for inspection and delivery*
- [24] ISO 6362-2, *Wrought aluminium and aluminium alloy extruded rods/bars, tubes and profiles — Part 2: Mechanical properties*
- [25] EN ISO 9606-2, *Qualification test of welders — Fusion welding — Part 2: Aluminium and aluminium alloys (ISO 9606-2:2004)*
- [26] EN ISO 15607, *Specification and qualification of welding procedures for metallic materials —General rules (ISO 15607:2003)*
- [27] ISO 10042, *Arc-welded joints in aluminium and its weldable alloys — Guidance on quality levels for imperfections*

